

MDC100-050101

50V, 10A Brushless Controller

User's Guide



ANAHEIM AUTOMATION

4985 E. Landon Drive Anaheim, CA 92807
e-mail: info@anaheimautomation.com

(714) 992-6990 fax: (714) 992-0471
website: www.anaheimautomation.com

MDC100-050101 Driver Features

- Maximum Current Limit Setting from 1.0-10.0 Amps (peak)
- Internal or External Potentiometer Speed Control
- 2-Quadrant Operation
- Hall Sensor Feedback
- Constant Velocity Mode
- Short Circuit Protection
- Requires 20 - 50 VDC
- Brake, Disable and Direction Inputs
- TTL-CMOS Compatible Inputs
- Compact Size (4.45"x2.66"x1.48")
- Dual Mounting Option
- Detachable, Screw type Terminal Blocks
- CE Certified and RoHS Compliant

General Description

The MDC100-050101 driver is designed to drive DC brushless motors at currents of up to 10A (peak) and 50V. Using hall sensor feedback, a constant velocity mode can be selected. The driver is protected against over current cycle-by-cycle, hall sensor error and under voltage. When an error occurs, a fault light is turned on to notify the user. Included on the drive is an internal potentiometer to control the maximum phase current allowed into the motor and an internal potentiometer to control the speed of the motor. An optional external potentiometer (10K) or external voltage (1.5-4VDC) can be used to control the speed as well. The direction of the motor can be preset by the direction control input. Other inputs to the drive include a dynamic brake and a motor disable input. When using the brake input, it overrides all other inputs into the driver.

Fault Protection

This driver is equipped with a FAULT LED to alert the user of the following conditions.

1. Invalid Sensor Input Code
2. Enable Input at Logic 0
3. Over Current. The driver is equipped with cycle-by-cycle current limiting.
4. Undervoltage Lockout activation at 9.1VDC for the input voltage and 4.5VDC for the Hall Sensor voltage.

Ordering Information

Part #	Description
MDC100-050101	Featured BLDC driver 10A, 50V
PSA24V2.7A	DC Power Supply 24VDC at 2.7 Amps
PSA40V4A	DC Power Supply 40VDC at 4 Amps
PSA40V8A	DC Power Supply 40VDC at 8 Amps
CBL-AA5420	Cable, 3 Pins 12in. Long, For External Pot

Specifications

Control Inputs: (TB2, Pins 3-5)

TTL-CMOS Compatible

Logic "0" = 0-0.8VDC

Logic "1" = OPEN

All three inputs (brake, enable and direction) are pulled up to through 40k ohm resistors.

Power Requirements: (TB2, Pins 1 and 2)

20VDC (min) - 50VDC (max)

Brake: (TB2, Pin 3)

Logic "1" (open) - Motor will not run and if running will decelerate rapidly

Logic "0" - Motor will run

Direction Control: (TB2, Pin 4)

Logic "1" (open) - Clockwise

Logic "0" - Counterclockwise

Enable: (TB2, Pin 5)

Logic "1" (open) - Motor is Enabled

Logic "0" - Motor is de-energized and will coast. This function will also cause the red Fault LED to illuminate

Speed: (JP3 or R13):

Internal/External Speed Potentiometer: 30% -100%

External Voltage: 1.5V - 4V

Output Current Rating:

Adjustable 1.0 - 10.0 amperes per phase maximum operating peak current
(0.5 - 5.0 amperes per phase maximum operating continuous current)

Operating Temperature

Heat Sink: 0°-70° C

Hall Sensor Power Output:

6.25V @30mA maximum. Typical current draw from hall sensors in 20mA.

All three Hall Sensor inputs are pulled up through 20K ohm resistors.

The external speed control potentiometer must be 10K Ohms.

Heating Considerations

The temperature of the heat sink should never be allowed to rise above 70°C. If necessary, mount the unit to an additional heat sink or are should be blown across the heat sink to maintain suitable temperatures.

Commutation Sequence

	Step					
	1	2	3	4	5	6
Phase A	+	Z	-	-	Z	+
Phase B	Z	+	+	Z	-	-
Phase C	-	-	Z	+	+	Z
Hall A	1	1	0	0	0	1
Hall B	0	1	1	1	0	0
Hall C	0	0	0	1	1	1

120° Hall Spacing Sequence Forward

	Step					
	1	2	3	4	5	6
Phase A	-	Z	+	+	Z	-
Phase B	Z	-	-	Z	+	+
Phase C	+	+	Z	-	-	Z
Hall A	1	1	0	0	0	1
Hall B	0	1	1	1	0	0
Hall C	0	0	0	1	1	1

120° Hall Spacing Sequence Reverse

	Step					
	1	2	3	4	5	6
Phase A	+	Z	-	-	Z	+
Phase B	Z	+	+	Z	-	-
Phase C	-	-	Z	+	+	Z
Hall A	1	1	1	0	0	0
Hall B	0	1	1	1	0	0
Hall C	0	0	1	1	1	0

60° Hall Spacing Sequence Forward

	Step					
	1	2	3	4	5	6
Phase A	-	Z	+	+	Z	-
Phase B	Z	-	-	Z	+	+
Phase C	+	+	Z	-	-	Z
Hall A	1	1	1	0	0	0
Hall B	0	1	1	1	0	0
Hall C	0	0	1	1	1	0

60° Hall Spacing Sequence Reverse

+ = Top Transistor ON, Bottom Transistor OFF, Current flows into this wire

- = Top Transistor OFF, Bottom Transistor ON, Current flows out of this wire

Z = Top Transistor OFF, Bottom Transistor OFF, No current into or out of this wire (High Impedance)

Motor Connection

Refer to the hookup diagram for typical driver applications. When connecting a motor for the first time, connect the hall sensor wires (5 of them) to the driver. **DO NOT CONNECT THE PHASES YET.** Turn on power and rotate the motor by hand. If the RED FAULT LED comes on, the hall phases are incorrectly wired. If the RED FAULT LED does not come on then the hall wires are connected correctly. Power the unit down and proceed to connect the motor phases. If the motor does not run or runs erratically, power down and check the speed potentiometer and make sure the phases are connected correctly. There are six different ways to connect the phase wires, and normally only two will allow the motor to rotate, but only one is correct. If the direction of the motor is changed and the no-load current of the motor is approximately the same and the motor runs smoothly in both directions then the phase wires are correct.

The wiring of the motor phases should be separated from the hall and input connections to not allow a possible source of interference.

Terminal and Dip Switch Descriptions

Pin #	Description
1	Phase A
2	Phase B
3	Phase C
4	Hall Sensor Power
5	Hall Sensor A
6	Hall Sensor B
7	Hall Sensor C
8	Hall Sensor Ground

TB1: Motor Terminals

Pin #	Description
1	Power In (20-50VDC)
2	Ground
3	Brake
4	Direction
5	Enable

TB2: Input Terminals

Pin #	Description
1	+4.0V (Pot Top)
2	Pot Wiper
3	GND (Pot Bottom)

JP3: 10K External Pot

Jumper Functions

Function	JP4	JP1	JP2
Constant Speed Mode (Closed Looped)	Open	---	---
Voltage Controlled Speed Mode (Open Loop)	1-2	---	---
60° Hall Sensor Spacing	---	Open	---
120° Hall Sensor Spacing	---	1-2	---
Internal Speed Control (R13)	---	---	1-2
External Speed Control (JP3)	---	---	2-3
Standard Product (Ready to Ship)	1-2	1-2	1-2

Speed Adjust Setting

There are two ways to set the speed on this drive. One is to use the on board potentiometer. The other is to use an external 10k potentiometer. To use the on board potentiometer, set jumper JP2 to position 1-2 (default). To use the external 10K potentiometer, set jumper JP2 to position 2-3.

The mating connector for the external 10K potentiometer is Molex part number 3-640440-3.

Motor Enable

The motor enable feature allows the de-energizing of the motor phases. An open input at this input causes the motor to run at the given speed, while a low at this input causes the motor to coast to a stop.

Motor Brake

The motor brake feature allows the stopping of a motor by shorting out the bottom drives of the three phases. A low at this input allows the motor to run, while an open input does not allow motor operation and if operating causes rapid deceleration.

Motor Direction

The motor direction feature allows the changing of the rotation of the motor. This input should not be changed while motion is in progress. An open input causes the motor to turn in the CW direction, while a low at this input causes the motor to turn in the CCW direction.

Jumper/Potentiometer Location

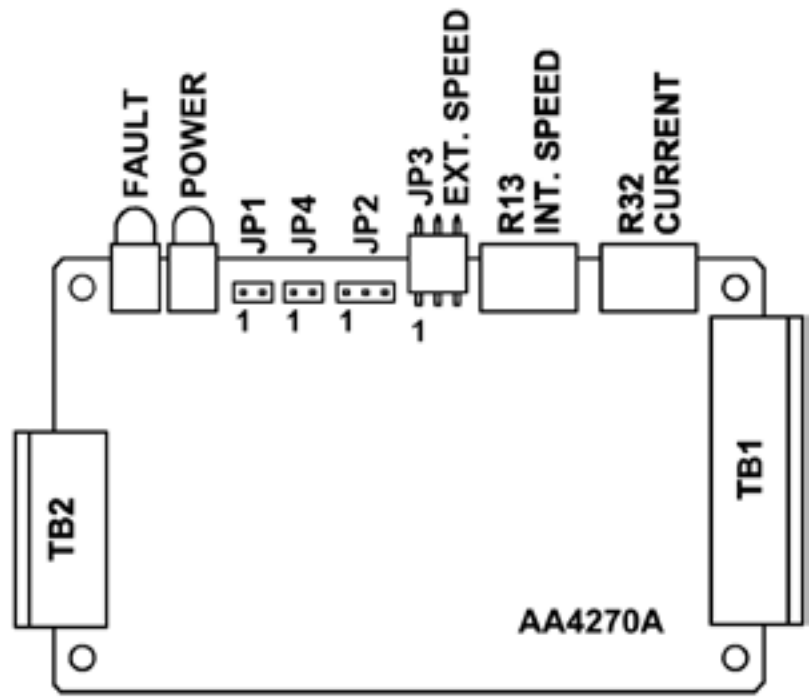

Typical Hookup Drawing

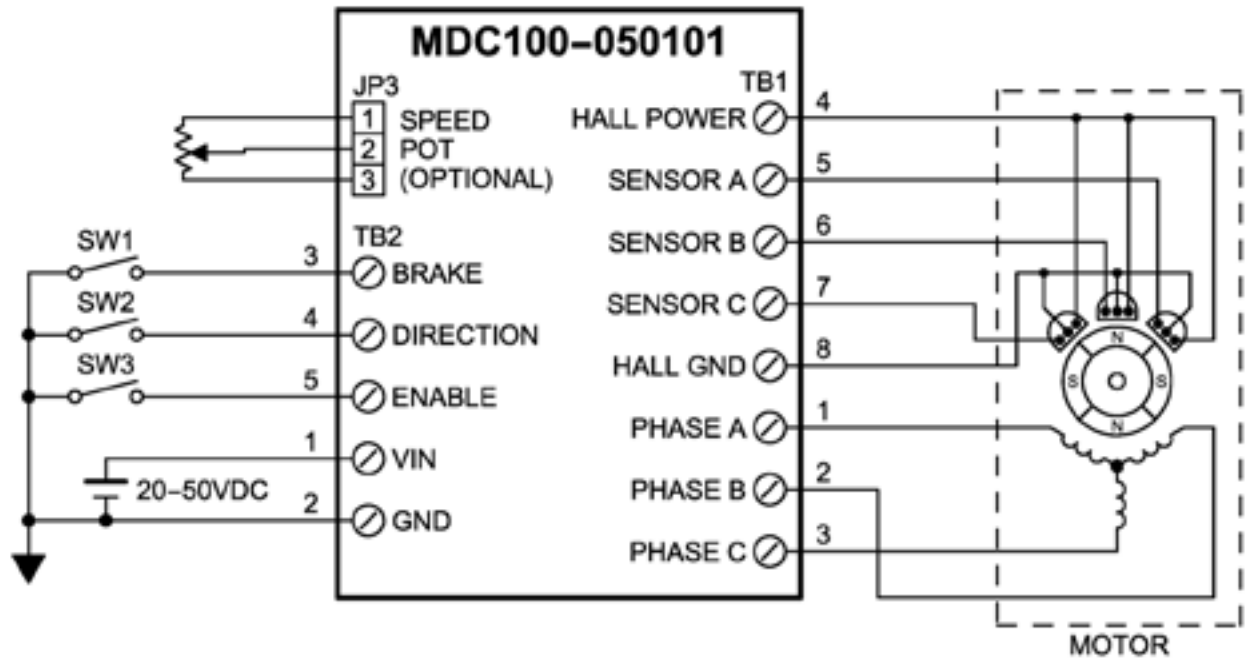

Dimensions

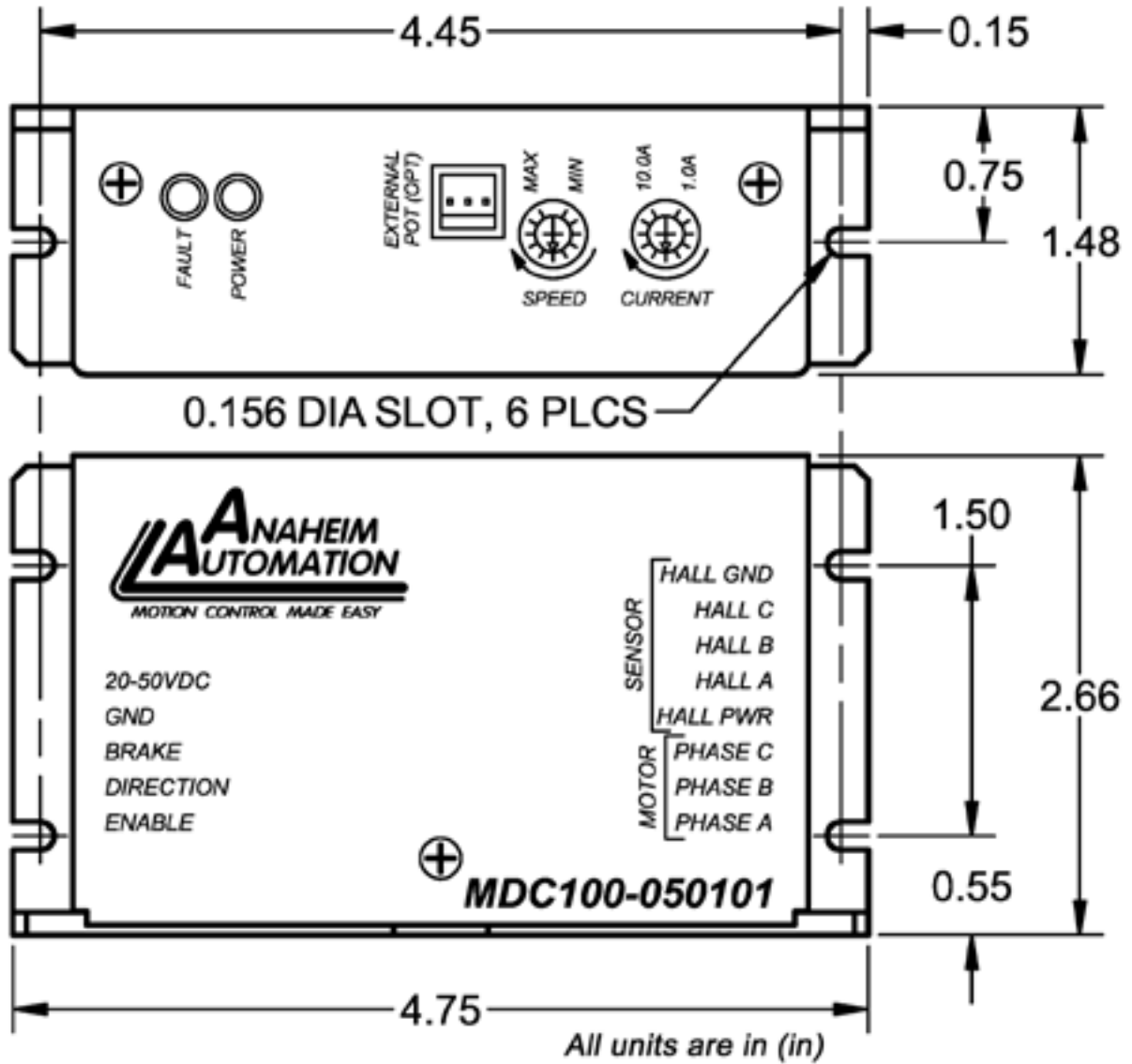

COPYRIGHT

Copyright 2007 by Anaheim Automation. All rights reserved. No part of this publication may be reproduced, transmitted, transcribed, stored in a retrieval system, or translated into any language, in any form or by any means, electronic, mechanical, magnetic, optical, chemical, manual, or otherwise, without the prior written permission of Anaheim Automation, 4985 E Landon Drive, Anaheim, CA 92807.

DISCLAIMER

Though every effort has been made to supply complete and accurate information in this manual, the contents are subject to change without notice or obligation to inform the buyer. **In no event will Anaheim Automation be liable for direct, indirect, special, incidental, or consequential damages arising out of the use or inability to use the product or documentation.**

Anaheim Automation's general policy does not recommend the use of its' products in life support applications wherein a failure or malfunction of the product may directly threaten life or injury. Per Anaheim Automation's Terms and Conditions, the user of Anaheim Automation products in life support applications assumes all risks of such use and indemnifies Anaheim Automation against all damages.

LIMITED WARRANTY

All Anaheim Automation products are warranted against defects in workmanship, materials and construction, when used under Normal Operating Conditions and when used in accordance with specifications. This warranty shall be in effect for a period of twelve months from the date of purchase or eighteen months from the date of manufacture, whichever comes first. **Warranty provisions may be voided if products are subjected to physical modifications, damage, abuse, or misuse.**

Anaheim Automation will repair or replace at its' option, any product which has been found to be defective and is within the warranty period, provided that the item is shipped freight prepaid, with previous authorization (RMA#) to Anaheim Automation's plant in Anaheim, California.

TECHNICAL SUPPORT

If you should require technical support or if you have problems using any of the equipment covered by this manual, please read the manual completely to see if it will answer the questions you have. If you need assistance beyond what this manual can provide, contact your Local Distributor where you purchased the unit, or contact the factory direct.

ANAHEIM AUTOMATION